

GE Fanuc IC695ALG708

Rx3i PacSystem

Analog Output Module, 8 channels,that is configurable IC695A
IC695AL IC695ALG

Company: Joyoung International Trading Co.,Limited

Atten: Smiling

Mobile/WhatsApp/Wechat:+86 18050035902

Email: info@htechplc.com

Website: <https://www.joyoungintl.com/>

Analog Output Module, 4 Channel Voltage / Current: IC695ALG704
Analog Output Module, 8 Channel Voltage / Current: IC695ALG708

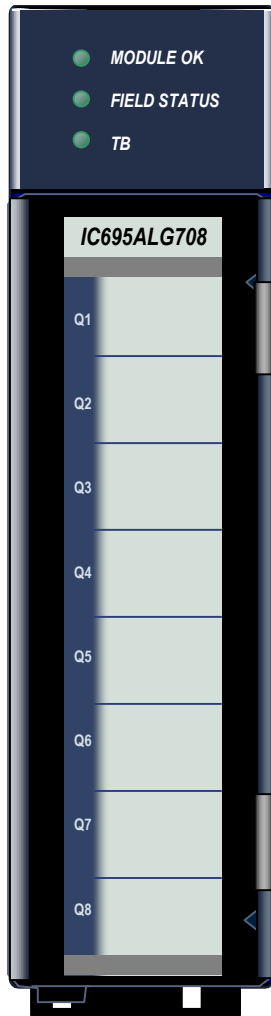

Non-Isolated Analog Voltage/Current Output module

IC695ALG704 provides 4 configurable voltage or current output channels. **Non-Isolated Analog Voltage/Current Output** module IC695ALG708, shown at left, provides 8 configurable voltage or current output channels. Analog channels can be configured for these output ranges:

- Current: 0 to 20mA, 4 to 20mA
- Voltage: +/- 10V, 0 to 10V

These modules can be used with a Box-style (IC694TBB032), Extended Box-style (IC694TBB132), Spring-style (IC694TBS032), or Extended Spring-style (IC694TBS132) Terminal Block. Extended terminal blocks provide the extra shroud depth needed for shielded wiring. See chapter 15 for more information about Terminal Blocks. Terminal Blocks are ordered separately.

These modules must be located in an RX3i Universal Backplane. They require an RX3i CPU with firmware version 3.0 or later. Machine Edition Version 5.0 SP3 Logic Developer-PLC or later must be used for configuration.

Isolated +24 VDC Power

The module must receive its 24 VDC power from an external source. The external source must be connected directly to the module's terminal block. It cannot be connected via the TB1 connector on the RX3i Universal Backplane. **Module Features**

- Completely software-configurable, no module jumpers to set
- Individually enable or disable channels
- Clamping and Alarm Limits
- Latching of Alarms
- Configurable output bias
- Rapid channel acquisition times based on filter frequency
- Full autocalibration
- On-board error-checking
- Configurable scaling and offsets per channel
- High alarm, low alarm, high-high alarm, low-low alarm detection and reporting selectable per channel
- Module fault reporting
- Configurable Hold Last State or Output Defaults

Specifications: IC695ALG704 and IC695ALG708

Output Ranges	Current: 0 to 20mA, 4 to 20mA Voltage: +/- 10V, 0 to 10V
Backplane Power Requirements	375 mA maximum at 3.3V
Power Dissipation within Module (V _{user} =24V)	IC695ALG704: 4.8 Watts maximum IC695ALG708: 7.25Watts maximum
Thermal Derating	IC695ALG704: None IC695ALG708: Voltage mode: none Current mode: See next page.
External Power Supply V _{user}	Voltage Range: +19.2V to +30VDC Current required for ALG704: 150mA maximum Current required for ALG708: 250mA maximum
Resolution	+/-10V: 15.9 bits, 0 to 10V: 14.9 bits, 0 to 20mA: 15.9 bits, 4 to 20mA : 15.6 bits
Output Data Format	Configurable as floating point IEEE 32 bit or 16-bit integer in a 32-bit field
Update Rate (Determined by I/O scan time, application dependent.)	8 milliseconds (approximate, all eight channels)
Output Overvoltage Protection	Current outputs only: -30V for 60 seconds, +30V for one hour
Calibrated Accuracy	Accurate to within 0.15% of full scale at 25°C Accurate to within 0.30% of full scale at 60°C In the presence of severe RF interference (IC 801-3, 10V/M), accuracy may be degraded to +/-1% FS.
Output Load Reactance	Current: 10μH maximum, Voltage: 1μF maximum
Maximum Output Load	Current: 850 Ohms maximum at V _{user} = 20V Voltage: 2 Kohms minimum
Output Gain Drift	Voltage output: 20ppm per degree C typical Current output: 35ppm per degree C typical
Output Settling Time	Voltage or current output: 2ms, 0 to 95%.
Isolation, Field to Backplane	2550VDC for one second
Maximum Compliance Voltage	V _{user} – 3V (minimum) to V _{user} (maximum)

Refer to Appendix A for product standards and general specifications.

Output Points vs. Temperature, Current Mode

Module IC695ALG704 has no thermal derating. Module IC695ALG708 has no thermal derating in voltage mode. Thermal deratings for module IC695ALG708 In current mode are shown below.

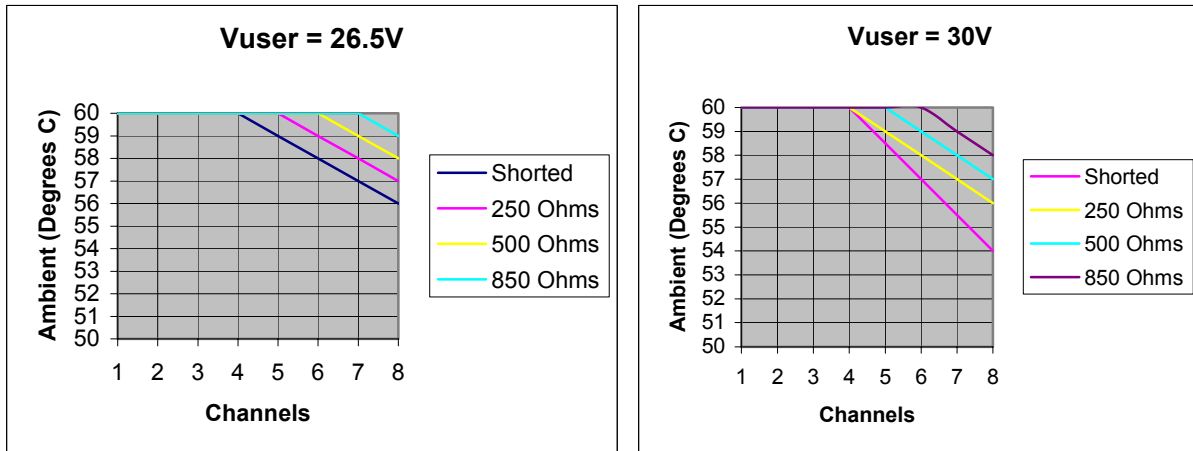

LEDs

The **Module OK** LED indicates module status. The **Field Status** LED indicates whether the external +24 VDC power supply is present and is above the minimum level and whether or not faults are present. All LEDs are powered from the backplane power bus.

LED	Indicates
Module OK	ON Green: Module OK and configured. Quick Flashing Green: Module performing powerup sequence. Slow Flashing Green or Amber: Module OK but not configured. OFF: Module is defective or no backplane power present
Field Status	ON Green No faults on any enabled channel, Terminal Block is present, and field power is present. ON Amber and TB Green: Terminal Block is installed, fault on at least one channel, or field power is not present. ON Amber and TB Red: Terminal Block not fully removed, field power still detected. OFF and TB Red: Terminal block not present and no field power is detected.
TB	ON Red: Terminal block not present or not fully seated. See above. ON Green: Terminal block is present. See above. OFF: No backplane power to module.

Configuration Parameters: IC695ALG704 and IC695ALG708

Module Parameters		
Parameter	Default	Description
Outputs Reference Address	%AQxxxxx	Starting address for the module's output data. This defaults to the next available %AQ block.
Outputs Reference Length	ALG704: 8	The number of words used for the module's output data. This parameter cannot be changed.
	ALG7088: 16	
Output Command Feedback Reference Address	%Alxxxxx	Starting address for the module's command feedback data. This defaults to the next available %Al address after a non-zero length is configured.
Output Command Feedback Length	0	The number of words used for the module's command feedback data. Length defaults to 0. It can be set to 8 or 16, depending on the module type being configured.
Diagnostic Reference Address	%lxxxxx	Starting address for the channel diagnostics status data. This defaults to the next available %l block.
Diagnostic Reference Length	0	Read Only. The number of bit reference bits required for the Channel Diagnostics data. Default is 0, which means mapping of Channel Diagnostics is disabled. Change this to a non-zero value to enable Channel Diagnostics mapping. Maximum length is 128 bits for module IC695ALG704 or 256 bits for module IC695ALG708.
Module Status Reference Address	%lxxxxx	Starting address for the module's status data. This defaults to the next available %l block.
Module Status Reference Length	0	Read Only. The number of bits (0 or 32) required for the Module Status data. Default is 0, which means mapping of Module Status data is disabled. Change this to a non-zero value to enable Module Status data mapping.

Continued...

Analog Output Commanded Feedback

The module returns a copy of the analog output data received from CPU in its corresponding channel analog input shared memory. Output Feedback can be monitored to check the values being sent to the channels. The data is in the same scaled format as the output data for each channel. During normal operation this feedback data should match the actual output data after one or more PLC scans of module inputs. During faults, ramping, overrange, and clamping conditions, the analog output data may differ from the commanded output.

OverTemperature

If OverTemperature is enabled, the module generates an OverTemperature alarm if the module's internal temperature is too great for the number of outputs that are on at the same time. In addition to the configurable options for OverTemperature fault reporting and interrupts, an over temperature condition is also indicated by the OverTemperature bit in the module's Status Reference data. Detection of the OverTemperature status bit is always enabled.

Module Parameters		
Parameter	Default	Description
I/O Scan Set	1	The scan set 1 – 32 to be assigned to the module by the RX3i CPU.
Channel Faults w/o Terminal Block	Disabled	Enabled / Disabled: Controls whether channel faults and configured alarm responses will be generated after a Terminal Block removal. The default setting of Disabled means channel faults and alarms are suppressed when the Terminal Block is removed. This parameter does not affect module faults including the Terminal Block loss/add fault generation.
Module Fault Reporting Enabled	Enabled	Enabled / Disabled. Controls whether the module will report faults resulting from either loss of field power or overtemperature conditions.
Field Power Removed Enabled	Enabled	Enabled / Disabled. With Module Fault Reporting enabled, this parameter controls reporting of Field Power Removed module faults.
Over Temp Enabled	Enabled	Enabled / Disabled. With Module Fault Reporting enabled, this parameter controls reporting of Overtemperature module faults.
Module Interrupt Reporting Enabled	Disabled	Enabled / Disabled.
Field Power Removed Enabled	Disabled	Enabled / Disabled. With Module Interrupt Reporting enabled, this parameter controls interrupts for Field Power Removed module faults.
Over Temp Enabled	Disabled	Enabled / Disabled. With Module Interrupt Reporting enabled, this parameter controls interrupts for Overtemperature module faults.
Range Type	Disabled Current	Sets up the type of output to be used for each channel. Choices are: Disabled Voltage, Disabled Current, Voltage/Current.
Range (Only for Range Type Voltage/Current)	-10V to +10V	For voltage/current: -10V to +10V, 0V to +10V, 4mA to 20 mA, 0mA to 20 mA.
Channel Value Format	32-bit Floating Point	16-bit integer or 32-bit floating point
Outputs Default	Force to Default Value	Controls the state the output will be set to in Outputs Disabled mode (stop), if a fault occurs, if power is lost, or if the configuration is cleared. Choices are Hold Last State, or default to a specific configured default value.

Continued ...

Range Type

Each channel on the module that will be used should be configured for Voltage/Current. Its voltage or current range and other parameters can then be configured as needed. If the channel output will not be used and is not wired, select either "Disabled" option. If a channel is disabled, it is not necessary to configure any of its other parameters.

If the channel is wired to a current output, but will not presently be used, select "Disabled Current". This will set the channel's current output to 0mA (the channel's voltage output will be non-zero).

If the channel is wired to a voltage output, but will not presently be used, select "Disabled Voltage". This will set the channel's voltage output to 0V (the channel's current output will be non-zero).

Output Defaults

If Hold Last State is enabled, an output will hold its last commanded value when the CPU indicates Outputs Not Enabled, or if one of the fault conditions listed below occurs. If Hold Last State is disabled, the output is commanded to go to the Default Value. The Default Value must be set within the selected output range. If both Default Value and Ramp Rate are enabled, the channel will ramp to the default value. Fault conditions are:

- CPU outputs are not enabled
- Backplane power is not ok. In that case, there is no ramping, even if ramping has been enabled.
- Loss of communications from CPU.
- Loss of I/O communications.
- Loss of field power.

Outputs Default Notes

- Hot Removal of the module in an I/O Enabled mode will cause all outputs to Hold Last State (even channels configured for Force to Default Value). If that operation is not desirable, the outputs can be forced to default by first turning off field power and removing the module's Terminal Block before hot-removing the module.
- Resetting the module using SVC_REQ 24 causes all channels to Hold Last State even if Default Value is configured. The application program must handle output defaulting before execution of the Service Request.
- Default Ramp Rate configuration is ignored if backplane power from the power supply is lost. Channels configured for Default Value go to the default value immediately.
- The first time a configuration is stored following a return of backplane power, the Default Ramp rate is not used. Any channel configured for Default Value goes to its default value immediately. If analog power was not lost and the same configuration is restored on the next powerup, the channel state is unchanged from the time the power was lost. The Default Ramp Rate is used for any subsequent reconfiguration.

Output Default Conditions and Actions

Condition	Hold Last State or Default Value	Default Ramp Rate Enabled	Outputs Enabled and Ramp Rate Enabled	Channel Output Setting (Except where indicated, field power is assumed to be present).
Outputs Enabled and No Faults	N/A	N/A	No	Output goes to its commanded value from reference memory; defaults don't apply.
	N/A	N/A	Yes	Output is ramped to the commanded output from reference memory at the Outputs Enabled ramp rate. Defaults don't apply.
Outputs Disabled, Fault Mode, or Reconfiguration	Default Value	No	N/A	Output is set to the Default Value
	Default Value	Yes	N/A	Output is ramped to the Default Value at the Default ramp rate, starting at the last commanded value before entering mode.
	Hold Last State	N/A	N/A	Output is held at the last commanded value
Loss of Backplane Power or First Configuration Store after Powerup	Default Value	N/A	N/A	Output is set to the Default Value.
	Hold Last State	N/A	N/A	Output is held at last commanded value.
Hot Removal, Reset with SVCREQ 24 or Cleared Configuration	N/A	N/A	N/A	Output is held at last commanded value.
Loss of Field Power	N/A	N/A	N/A	All outputs go to 0V and 0mA.

Channel Parameters, continued		
Parameter	Default	Description
High Scale Value (Eng Units)	The defaults for the 4 Scaling parameters depend on the configured Range Type and Range. Each Range and Range Type have a different set of defaults.	Note: Scaling is disabled if both High Scale Eng. Units equals High Scale A/D Units and Low Scale Eng. Units equals Low Scale A/D Units. Default = High A/D Limit of selected range type.
Low Scale Value (Eng Units)		Default is Low A/D Limit of selected range type. Must be lower than the high scaling value.
High Scale Value (A/D Units)		Default is High A/D Limit of selected range type. Must be greater than the low scaling value.
Low Scale Value (A/D Units)		Default is Low A/D Limit of selected range type.

Continued ...

Output Scaling

By default, the module converts a floating point value from the CPU into a voltage or current output over the entire span of its configured Range. For example, if the Range of a channel is 4 to 20mA, the module accepts channel output values from 4.000 to 20.000. By modifying one or more of the four channel scaling parameters (Low/High Scale Value parameters) from their defaults, the scaled Engineering Unit range can be changed for a specific application. Scaling is always linear and inverse scaling is possible. All alarm values apply to the scaled Engineering Units value, not to the A/D units value.

The scaling parameters only set up the linear relationship between two sets of corresponding values. They do not have to be the limits of the output.

Example

In this example, the application should interpret 32000 counts as +10V and -32000 counts as -10V . The following channel configuration will scale a +/-10V output channel to +/-32000 counts.

- Channel Value Format = 16 Bit Integer
- High Scale Value (Eng Units) = 32000.0
- Low Scale Value (Eng Units) = -32000.0
- High Scale Value (A/D Units) = 10.000
- Low Scale Value (A/D Units) = -10.000

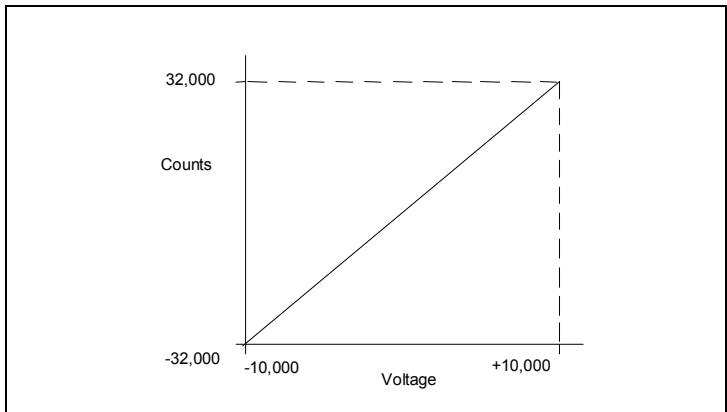

Channel Parameters, continued		
Parameter	Default	Description
High Alarm (Eng Units)	The defaults depend on the configured Range.	All of the alarm parameters are specified in Engineering Units. When the configured value is reached or below (above), a Low (High) Alarm is triggered.
Low Alarm (Eng Units)		
Outputs Enabled Ramp Rate (Eng Units)	0.0	The rate in Engineering Units at which the output will change during normal operation.
Default Ramp Rate (Eng Units)	0.0	The rate in Engineering Units at which the output will change if a fault condition occurs or if outputs are not enabled.
Output Clamping Enabled	Disabled	Enabled / Disabled. See description below.
Upper Clamp Limit (Eng Units)	The defaults depend on the configured Range.	The Upper Clamp Limit must be greater than the Lower Clamp Limit. This parameter can be used to restrict the output to a range that is narrower than its configured Range Type. For example, a channel configured for –10V to +10V could be restricted to -8V to +7.5V.
Lower Clamp Limit (Eng Units)		
Default Value (Eng Units)	0.0	If Hold Last State is disabled, the output is commanded to go to the Default Vale when the CPU is not in Outputs Enabled mode or under certain fault conditions.
User Offset (Eng Units)	0.0	A configurable value that can be used to change the base of the channel. This value is added to the scaled value of the channel before alarm-checking.

Continued ...

Lower, Upper Clamp and Alarms

Alarms can be used to indicate when the module has been commanded to meet or exceed the configured high or low limits for each channel. These are set at six configurable alarm trigger points:

- High Alarm and Low Alarm
- Upper Clamp and Lower Clamp
- Overrange and Underrange Alarm

Each alarm is individually configurable per channel to generate diagnostics bit status, fault alarms, or interrupt alarms.

If a channel is commanded higher than the Upper Clamp value, the output is set to the Upper Clamp value and an Upper Clamp condition is indicated. If a channel is commanded lower than the Lower Clamp value, the output is set to the Lower Clamp value and a Lower Clamp condition is indicated.

The High and Low Alarm checks are performed on the engineering units output value after possibly being adjusted by ramping, clamping, and fault conditions.

Channel Parameters, continued		
Parameter	Default	Description
Diagnostic Reporting Enable <i>If Diagnostic Reporting is enabled, the additional parameters listed below can be used to enable specific types of alarms.</i>	Disabled	<i>Diagnostic Reporting Enable options</i> are used to enable reference memory reporting of alarms into the Diagnostic Reference area. <i>Fault Reporting Enable options</i> enable fault logging of alarms into the I/O Fault Table.
Fault Reporting Enable <i>If Fault Reporting is enabled, the additional parameters listed below can be used to enable specific types of Faults.</i>	Disabled	These parameters enable or disable the individual diagnostics features of a channel. When any of these parameters is enabled, the module uses associated parameters to perform the enabled feature.
<i>Interrupts Enable</i>	Disabled	<p>For example, if Over Range is enabled in the “Diagnostic Reporting Enable” menu, the module will set the Over Range bit in the Diagnostic Reference for the channel.</p> <p>If any of these parameters is disabled, the module does not react to the associated alarm conditions.</p> <p><i>For example, if Low Alarm Enable is set to Disabled in the “Fault Reporting Enable” menu, the Low Alarm fault is not logged in the I/O Fault Table when Low Alarm is detected on the channel.</i></p>
<i>Low Alarm Enable</i>	Disabled	
<i>High Alarm Enable</i>	Disabled	
<i>Under Range Enable</i>	Disabled	
<i>Over Range Enable</i>	Disabled	
<i>Lower Clamp Alarm Enable</i>	Disabled	
<i>Upper Clamp Alarm Enable</i>	Disabled	

Alarming and Fault Reporting

The Diagnostic Reporting Enable, Fault Reporting Enable, and Interrupt Enable configuration parameters can be used to enable different types of responses for individual channel alarms. By default, all responses are disabled on every channel. Any combination of alarm enables can be configured for each channel.

- If Diagnostic Reporting is enabled, the module reports channel alarms in reference memory at the channel's Diagnostic Reference address.
- If Fault Reporting is enabled, the module logs a fault log in the I/O Fault table for each occurrence of a channel alarm.
- If Interrupts are enabled, an alarm can trigger execution of an Interrupt Block in the application program, as explained below.

Using Interrupts

To properly configure an I/O Interrupt, the Interrupt enable bit or bits must be set in the module's configuration. In addition, the program block that should be executed in response to the channel interrupt must be mapped to the corresponding channel's reference address.

Example:

In this example, the Channel Values Reference Address block is mapped to %AQ0001-%AQ0008. An I/O Interrupt block should be triggered if a High Alarm condition occurs on channel 2.

- Configure the High-Alarm condition.
- Set the High-Alarm Interrupt Enable flag for Channel 2 in the module configuration.

Channel 2's reference address corresponds to %AQ00003 (2 Words per channel), so the interrupt program block Scheduling properties should be set for the "I/O Interrupt" Type and "%AQ0003" as the Trigger.

Fault Reporting and Interrupts

These modules have separate enable/disable options for Diagnostic Reporting and Interrupts. Normally, disabling a diagnostic (such as Low/High Alarm or Over/Under range) in the configuration means that its diagnostic bit is never set. However, if interrupts are enabled for a condition and that interrupt occurs, the diagnostic bit for that condition is also set during the I/O Interrupt block logic execution. The next PLC input scan always clears this interrupt status bit back to 0, because Diagnostic Reporting has it disabled.

Module Data: IC695ALG704 and IC695ALG708

The module receives its channel data from its configured output words, beginning at its assigned Channel Value Reference Address. Each channel occupies 2 words (whether the channel is used or not):

Channel Value Reference Address	Contains this Input
+0, 1	Channel 1
+2, 3	Channel 2
+4, 5	Channel 3
+6, 7	Channel 4
<i>For Module IC695ALG708 Only:</i>	
+8, 9	Channel 5
+10, 11	Channel 6
+12, 13	Channel 7
+14, 15	Channel 8

Depending on its configured Channel Value Format, each enabled channel output reference location is read as a 32-bit floating point or 16-bit integer value.

In the 16-bit integer mode, low word of the 32-bit channel data area contains the 16-bit integer channel value. The high word (upper 16-bits) of the 32-bits is ignored. The full range of the 16-bit integer is a signed decimal value from +32767 to -32768.

Because the channel reference location is 32 bits, it is possible for the application program to write 32-bit signed decimal values to the output reference. However, the program logic must restrict the magnitude of the value to the range +32767 to -32768. Exceeding this range will result in misinterpretation of the sign bit, and incorrect output channel operation.

Channel Diagnostic Data

In addition to the input data from field devices, the module can be configured to report channel diagnostics status data to the CPU. The CPU stores this data at the module's configured *Diagnostic Reference Address*. Use of this feature is optional.

The diagnostics data each channel occupies 2 words (whether the channel is used or not):

Diagnostic Reference Address	Contains Diagnostics Data for:
+0, 1	Channel 1
+2, 3	Channel 2
+4, 5	Channel 3
+6, 7	Channel 4
<i>For Module IC695ALG708 Only:</i>	
+8, 9	Channel 5
+10, 11	Channel 6
+12, 13	Channel 7
+14, 15	Channel 8

When a diagnostic bit equals 1, the alarm or fault condition is present on the channel. When a bit equals 0 the alarm or fault condition is either not present or detection is not enabled in the configuration for that channel.

For each channel, the format of this data is:

Bit	Description
1	Low Alarm Exceeded = 1
2	High Alarm Exceeded = 1
3	Underrange = 1
4	Overrange = 1
5 – 20	Reserved (set to 0).
21	Lower Clamp Active = 1
22	Upper Clamp Active = 1
23 - 32	Reserved (set to 0).

Module Status Data

The module can also optionally be configured to return 4 bits of module status data to the CPU. The CPU stores this data in the module's 32-bit configured Module Status Data reference area.

Bit	Description
1	Module OK (1 = OK, 0 = failure, or module is not present)
2	Terminal Block Present (1 = Present, 0 = Not present)
3	Field Power (0 = Present, 1 = Not present)
4	Module Overtemperature (0 = Not overtemperature, 1 = Approaching or exceeding overtemperature)
5 - 32	Reserved

Terminal Block Detection

The module automatically checks for the presence of a Terminal Block.

The module's TB LED indicates the state of the terminal block. It is green when the Terminal Block is present or red if it is not.

Faults are automatically logged in the CPU's I/O Fault table when the terminal block is inserted or removed from a configured module in the system. The fault type is Field Fault and the fault description indicates whether the fault is a "Loss of terminal block" or an "Addition of terminal block". If a Terminal Block is not present while a configuration is being stored, a "Loss of terminal block" fault is logged.

Bit 2 of the Module Status Reference indicates the status of the terminal block. To enable Module Status reporting, the Module Status Reference must be configured. During operation, the PLC must be in an I/O Enabled mode for the current Module Status to be scanned and updated in reference memory.

Field Wiring: IC695ALG704 and IC695ALG708

The table below lists wiring connections for the Non-Isolated Analog Output Modules. There are no shield terminals. For shielding, tie cable shields to the ground bar along the bottom of the backplane. M3 tapped holes are provide in the ground bar for this purpose.

Terminal	IC695ALG704	IC695ALG708	IC695ALG704	IC695ALG708	Terminal
1	Channel 2 Voltage Out		Channel 1 Voltage Out		19
2	Channel 2 Current Out		Channel 1 Current Out		20
3	Common (COM)		Common (COM)		21
4	Channel 4 Voltage Out		Channel 3 Voltage Out		22
5	Channel 4 Current Out		Channel 3 Current Out		23
6	Common (COM)		Common (COM)		24
7	No Connection	Channel 6 Voltage Out	No Connection	Channel 5 Voltage Out	25
8	No Connection	Channel 6 Current Out	No Connection	Channel 5 Current Out	26
9	Common (COM)		Common (COM)		27
10	No Connection	Channel 8 Voltage Out	No Connection	Channel 7 Voltage Out	28
11	No Connection	Channel 8 Current Out	No Connection	Channel 7 Current Out	29
12	Common (COM)		Common (COM)		30
13	Common (COM)		Common (COM)		31
14	Common (COM)		Common (COM)		32
15	Common (COM)		Common (COM)		33
16	Common (COM)		Common (COM)		34
17	Common (COM)		Common (COM)		35
18	Common (COM)		+24V In		36

Each channel can be individually-configured to operate as a voltage output or a current output, not both simultaneously. All the common terminals are connected together internally, so any common terminal can be used for the negative lead of the external power supply.

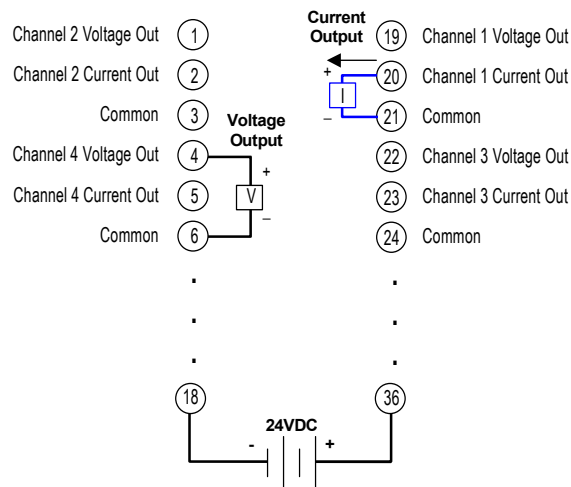

Chapter 11

Analog Modules with HART Communications

This chapter describes Non-isolated Analog modules that provide HART communications for PACSystems RX3i controllers.

- Overview of HART Communications for PACSystems RX3i
- Module Descriptions, specifications, configuration parameters, and wiring information for:
 - Analog Input Module, 16/ 8 Channel Voltage / Current, HART: IC695ALG626
 - Analog Input Module, 8/4 Channel Voltage / Current, HART: IC695ALG628
 - Analog Output Module, 8 Channel Voltage/Current with HART: IC695ALG728
- COMMREQs for HART Modules
- HART Function Blocks for the Application Program
- Converting HART Data to / from RX3i Format

Overview of HART Communications for PACSystems RX3i

HART® (highway addressable remote transducer) protocol is an open standard owned by the members of the HART Communication Foundation. HART combines simultaneous 4-20mA current loop operation with digital communications using the same signal. It imposes a frequency-shifted AC signal on the normal 4 to 20mA current loop signal. Both analog and digital communications signals utilize the same set of wires without signal disruptions. For more information about HART, refer to the HART Application Guide, published by the HART Communication Foundation (www.hartcomm.org).

For PACSystems RX3i, point-to-point HART communications are provided by the three analog modules described in this chapter. Each channel on modules IC695ALG626, ALG628, and ALG728 can utilize HART 5.0 protocol to communicate with HART field devices. The HART devices must be revision 5.0 or later; earlier HART versions use a different messaging format that is not supported by the RX3i analog HART modules.

To utilize HART communications, a channel must be configured for HART operation as described in this chapter, and for 4-20mA current range. During module operation, the 4-20mA channel signal communicates one process variable. Additional process variables, configuration data, and device data are transferred digitally using the HART protocol. The 4-20mA signal is not affected by the HART signal.

RX3i HART Module Operation

HART is a master-slave communications protocol. An RX3i analog module with HART communications act as the Primary Master for a single HART field device and a Secondary Master, which is usually an optional handheld device. RX3i analog HART modules do not support multi-drop communications consisting of multiple field devices on a channel, or Burst Mode transmissions. However, they do support the HART concept of multiple "slots" on a field device.

The HART module automatically issues HART commands to any HART device that is present and enabled in configuration. The response data from these commands is maintained within the HART module's internal memory and is optionally available for input scanning of HART Data, or for response to the Get Device Information COMMREQ (command 1). During start-up or after a device configuration changes (HART device "configuration changed" bit is set), the HART module executes HART commands 0, 3, 12, 13, 15, 16, 33, 48, and 50 (All Data). In addition, the module periodically re-issues command #3 and also command #33 if HART Slot Variables are enabled (Dynamic Data). The period with which the Dynamic Data commands are issued depends on the configuration for HART Pass-Thru Service Options and the number of HART devices enabled in a modem group. HART command #59 is issued each time a HART device initializes to set the number of preambles to 5.

An RX3i HART module can be configured to make HART device data available for input scanning by using the HART Data Scan Control. With this option as part of normal input scanning from the module, the automatic HART command response data from each device is formatted and written to reference memory at the HART Data Reference Address. In addition to the disabled option, there are two other configuration options for the HART Data Scan Control. Dynamic Only periodically updates inputs with data from HART command #3 and provides the resulting PV, SV, TV, and FV variables to input reference memory. If HART Slot Variables are enabled, the command #33 slot variable values are also updated automatically. Dynamic Only data also includes the most current Communication and Device Status. The All Data option provides the same information as the Dynamic Only option, plus additional data from HART commands 0, 12, 13, 15, 16, 48, and 50.

In many applications, the Dynamic Only option should provide all of the needed HART variables. The variable data updates automatically in the HART module's input scan data (no COMMREQ trigger is needed). If the Dynamic Only data is not sufficient, additional HART data may be accessed automatically using the All Data option. Enabling either the Dynamic Only or All Data option affects the PLC I/O sweep time because of increased input scan data from the module. If neither scan option provides all the necessary inputs or if additional control of HART devices is needed, COMMREQs are available that provide additional functionality or replace the automatic input scanning. Two COMMREQs are available. The Get Device Information COMMREQ (Command 1) returns the same data for a HART device as the All Data scan option; however, this COMMREQ must be reissued in logic to get updates of the variable data. The HART Pass-Thru COMMREQ is capable of executing any HART command including manufacturer-specific commands; however, care must be used to correctly format HART command request and response data which must be byte packed and big-endian formatted. Instructions are given in this chapter.

Using DO I/O with HART Modules

The HART modules fully support the DOIO function block if only analog channel values and analog diagnostics are scanned. However, DOIO will not function under certain conditions when HART devices are enabled and the HART Data Scan Control is set to either All Data or Dynamic Only. Because of CPU limitations, only modules with input scan sizes of 256 bytes or less can use the DOIO function block. HART modules will function normally with DOIO unless the input scan size becomes greater than 256 bytes (this input size limitation may be increased or eliminated in future releases). When this input scan size is exceeded, any attempt to use DOIO for HART module inputs or outputs will fail, and the DOIO function will not pass power flow. The exact number of devices that can be enabled and DOIO continue to operate depends on the module. For ALG628 and ALG728, the number of devices that can be enabled with All Data selected is only 1, and the number of devices with Dynamic Only selected is 5. For ALG626, the number devices enabled with Dynamic Only selected is 3, and DOIO will not function at all for ALG626 if any HART devices are enabled with All Data selected.